



## **MTC 1: Product Information Worksheet**

**Category:** 2 – Work Surface Products

**Subcategory:** 2B-2, Typical 2B2-2

- a) **Series:** Manhattan
- b) **Component Part Number / Ordering Code:** MRTEHA
- c) **Component Finishes:** Various. See attached.
- d) **Component Height:** 24"-42", electric height adjustable
- e) **Component Width:** 24"
- f) **Component Length:** 60"

QUOTE / SALES ORDER <b>Q151236</b>	PRODUCT LINE <b>TABLES</b>	REV. RELEASED FOR QUOTE	DESCRIPTION	DATE 1/10/23	DRAWN BY AC
DRAWING NO. <b>Q151236-J</b>		A			
		B			
		C			
CAD FILE <b>Q151236.dwg</b>	UNITS <b>INCHES</b>	D			
		E			
		F			
DRAWN BY <b>A CORDOVA</b>	REVIEWED BY C.S. ORDER ENTRY - PRINT NAME	<b>FOR QUOTING PURPOSES</b>		<b>NOT TO SCALE</b>	



**CONCEPT DRAWING ONLY. DO NOT RELEASE FOR PRODUCTION**

**NOTES**  
 TOP SIZE/SHAPE: 24/ 38.125 x 60 - Custom Shape  
 EDGE DETAIL: PBM  
 BASE: (3) MNTEHA  
 ELECTRICAL:  
 HARDWARE:



ELECTRICAL CUTOUT

TOP/PLAN VIEW

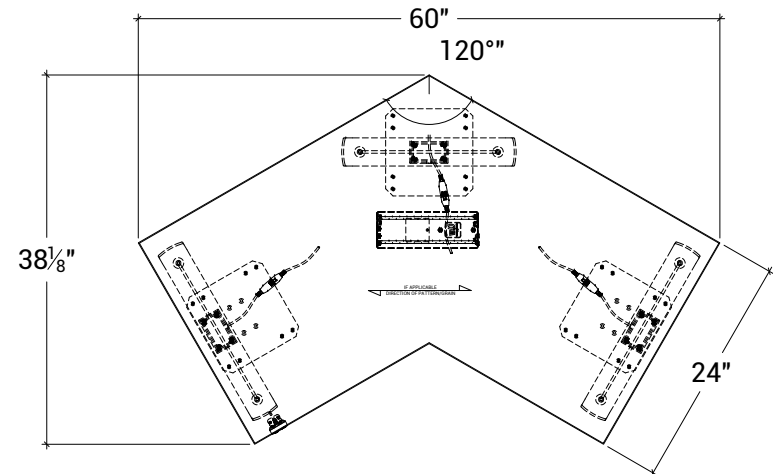

FRONT VIEW

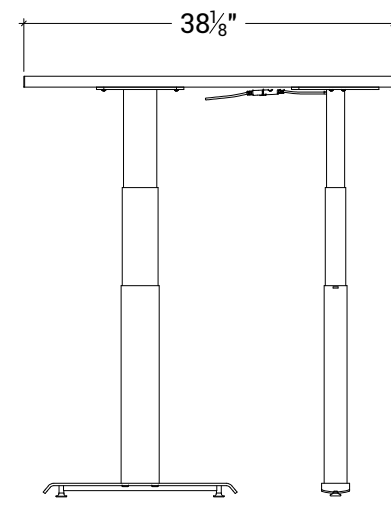
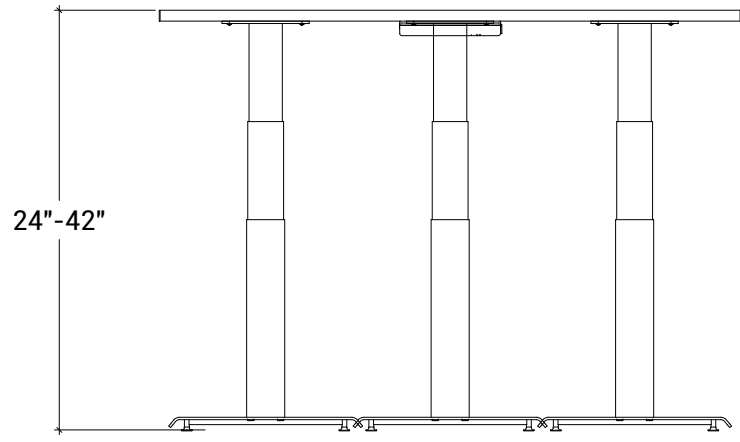

SIDE VIEW

Q151236-J

DWG STATUS	MATERIAL	UNITS & TOLERANCE
---		Unless otherwise noted: Units are inches Dims <= 5": +/- 0.03" Dims > 5": +/- 0.0625"

PRODUCT LINE: ---

ITEM DESCRIPTION: ---

SPEC FURNITURE Inc. claims proprietary right to the material disclosed hereon. This drawing and/or technical information is the property of SPEC FURNITURE Inc. and is issued in confidence for the use only as authorized, and may not be reproduced or described or shown to others without written permission from SPEC FURNITURE Inc.

REV.	DATE	DESCRIPTION OF CHANGE	ECN/NPD #	CHANGE BY
A	01/13/23	RELEASED FOR QUOTE	--	AC

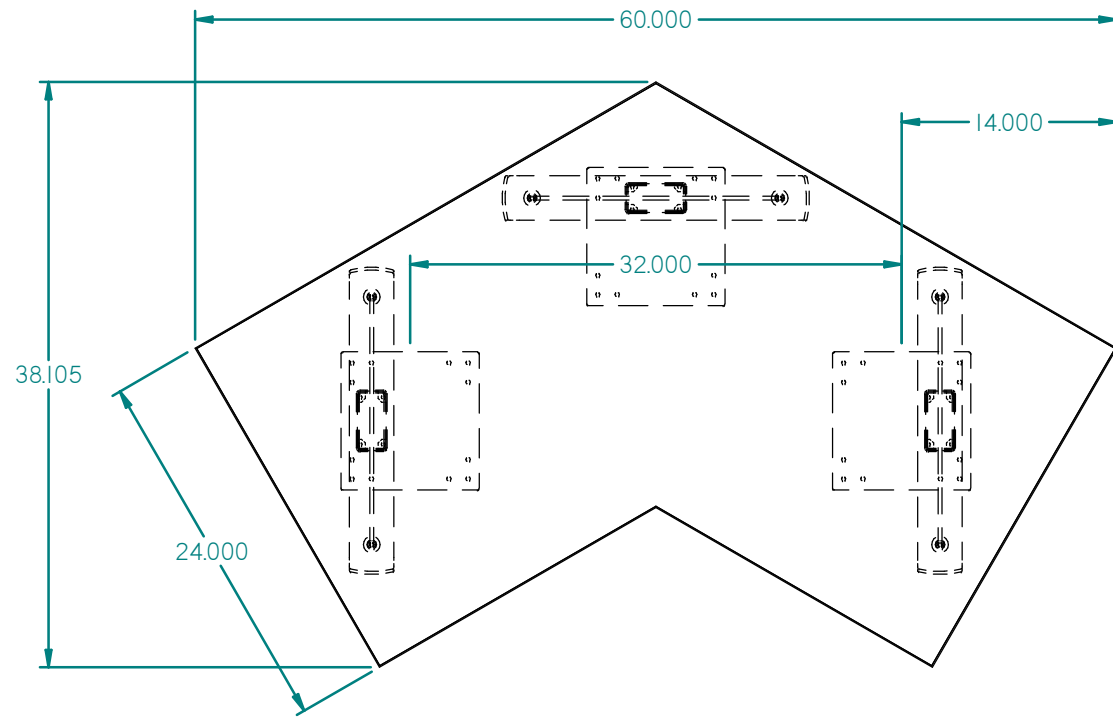

Height - 24" to 42"H

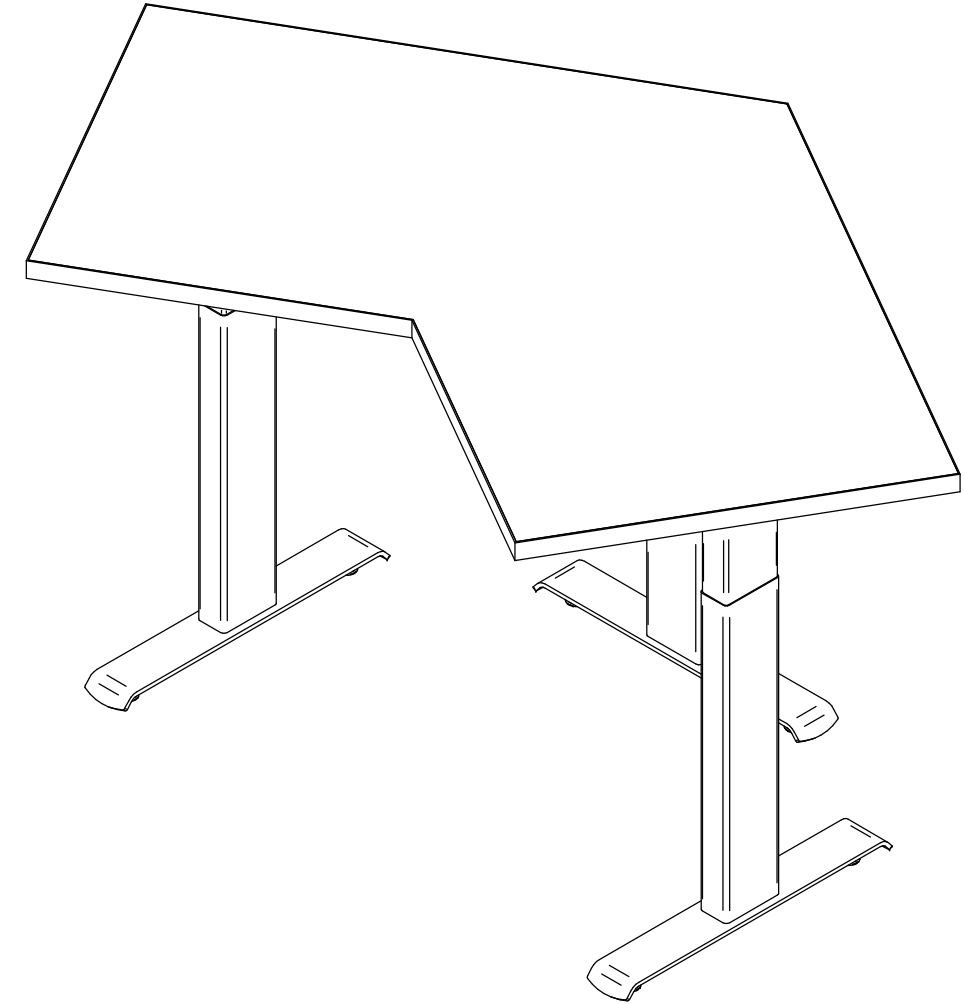
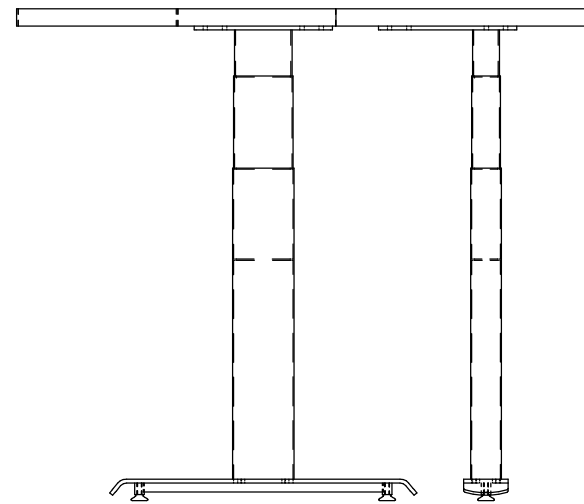
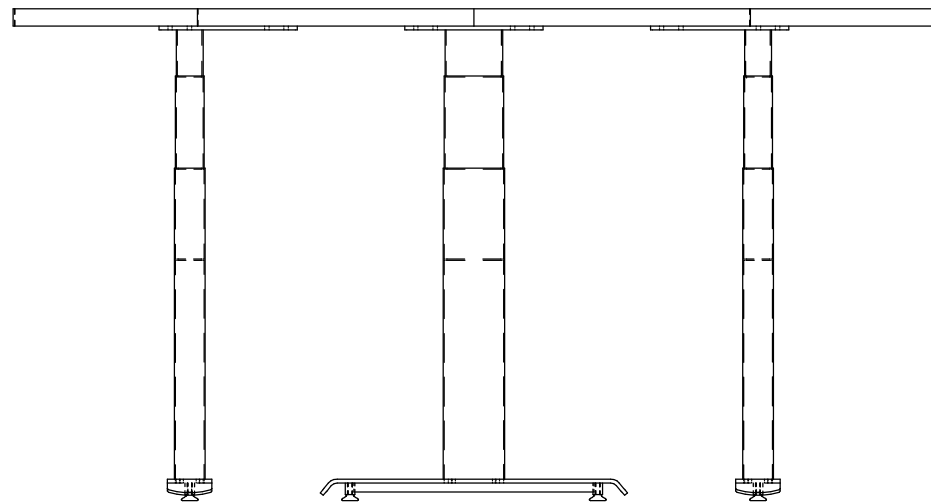

NOT TO SCALE